

SPECIAL ACCESS SERVICE

I. PROVISION OF SPECIAL ACCESS SERVICE

Special Access Service provides a dedicated transmission path to connect customer designated premises*, either directly or through a Telephone Company hub where bridging or multiplexing functions are performed. Special Access Service may also be combined with Switched Access Services in the provision of a customer's intrastate communications service (WATS, 800 or WATS-type Services). Special Access Service includes all exchange access not utilizing Telephone Company central office switches.

Certain Special Access Services listed in this section of the tariff may not be currently offered in all Telephone Company locations but may be provided upon customer request, on an individual case basis, if facilities can be made available with reasonable effort. The Telephone Company will work cooperatively with the customer to provide the service on a timely basis.

A. Circuit Types

There are five types of circuits used to provide Special Access Services:

- Voice Grade (VG)
- Program Audio (AP)
- Video (TV)
- Digital Data (DA)
- High Capacity (HC)

These circuits can be either analog or digital. Analog circuits are differentiated by frequency spectrum and bandwidth. Digital connections are differentiated by bit rate.

Telephone Company Centrex CO-like switches are considered to be customer premises for purposes of this tariff.

SPECIAL ACCESS SERVICE

I. PROVISION OF SPECIAL ACCESS SERVICE (Continued)

A. Circuit Types (Continued)

Each of the five circuits has its own characteristics. All of the circuit types are subdivided by one or more of the following:

- Transmission specifications,
- Bandwidth,
- Speed (i.e., bit rate),
- Spectrum

The circuit descriptions set forth in this section specify the characteristics of the basic circuit and indicates whether the circuit is provided between customer designated premises or between a customer designated premises and a Telephone Company hub where bridging or multiplexing functions are performed, or between a customer designated premises and a Telephone Company office capable of combining switched or special access services or a WATS serving office.

Customers can order a basic circuit and select from a list of available technical specifications packages (customized or pre-defined), channel interfaces, and optional features to design a circuit which meets the customer's specific communications needs. For purposes of ordering circuits, each has been identified as a type of Special Access circuit. However, such identification is not intended to limit a customer's use of the circuit, nor to imply that a circuit is limited to a particular use.

The optional features and functions available with each type of basic circuit are included in the individual service description sections following. The optional features and functions information also indicates with which technical specifications packages they are available.

When a customized circuit is ordered, the Telephone Company may determine that Additional Engineering is required to meet the customer's request for service. The customer will be notified whether Additional Engineering charges apply and will be given an estimate of the hours to be billed before any further action is taken on the order. Additional engineering charges are determined as set forth in Section 7, I. following.

Issued: 3/31/06
Effective: 3/8/06
By: Hopi Telecommunications, Inc.

SPECIAL ACCESS SERVICE

I. PROVISION OF SPECIAL ACCESS SERVICE (Continued)

B. Service Configurations

1. Two-Point Service

A two-point service connects two customer designated premises, either on a directly connected basis or through a hub where multiplexing functions are performed. A Voice Grade Special Access Circuit may be provided as a two-point service connecting an end user premise and a Telephone Company switch when Special Access is used in connection with Switched Access as set forth in Section 5, III.B.20. for Combined Access Service Arrangements. All types of Special Access Service may be provided as two-point service.

Issued: 3/31/06
Effective: 3/8/06
By: Hopi Telecommunications, Inc.

SPECIAL ACCESS SERVICE

I. PROVISION OF SPECIAL ACCESS SERVICE (Continued)

B. Service Configurations

1. Two-Point Service

The following diagram depicts an example of a two-point Voice Grade service connecting two customer designated premises location 15 miles apart. The service is provided with the optional feature of C-Type conditioning.

CT - Circuit Termination
CM - Circuit Mileage SWC - Serving Wire Center

Applicable rate elements are:

- Circuit Termination (2 applicable)
- Circuit Mileage (fixed rate plus rate per airline mile between SWC)
- C-Type Conditioning Optional Feature

In addition, charges for additional Optional Features and Functions may apply.

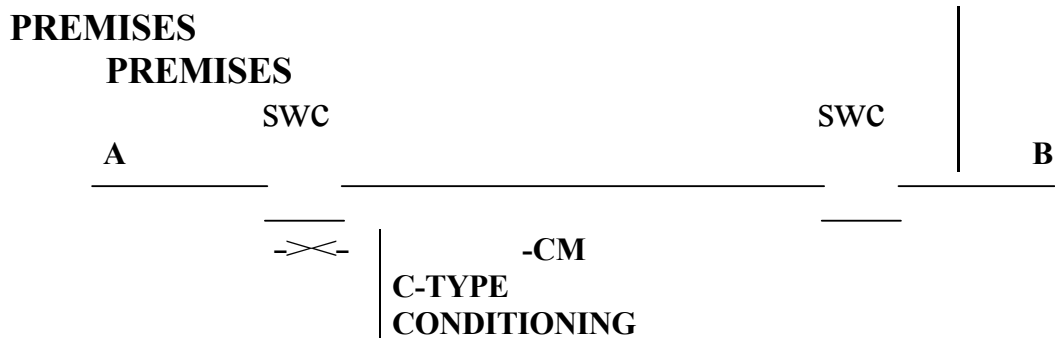

Issued: 3/31/06
Effective: 3/8/06
By: Hopi Telecommunications, Inc.

SPECIAL ACCESS SERVICE

I. PROVISION OF SPECIAL ACCESS SERVICE (Continued)

B. Service Configurations (Continued)

2. Multipoint Service

Multipoint service connects three or more customer designated premises through a Telephone Company hub (i.e., bridging locations). Only certain types of Special Access Service are provided as multipoint service. These are so designated in the Service Description for the appropriate circuit.

The circuit between hubs on a multipoint service is a mid-link. There is not limitation on the number of mid-links, but the use of more than three mid-links in tandem may degrade the quality of multipoint facilities.

Multipoint service utilizing a customized technical specifications package, as set forth in I.C., will be provided when technically possible.

When ordering, the customer will specify the desired bridging hub(s). NATIONAL EXCHANGE CARRIER ASSOCIATION TARIFF FCC NO. 4 identifies serving wire centers, hub locations and the type of bridging functions available.

SPECIAL ACCESS SERVICE

I. PROVISION OF SPECIAL ACCESS SERVICE (Continued)

B. Service Configurations (Continued)

2. Multipoint Service (Continued)

The following diagram depicts an example of a Voice Grade multipoint service connecting four customer premises via two customer specified bridging hubs.

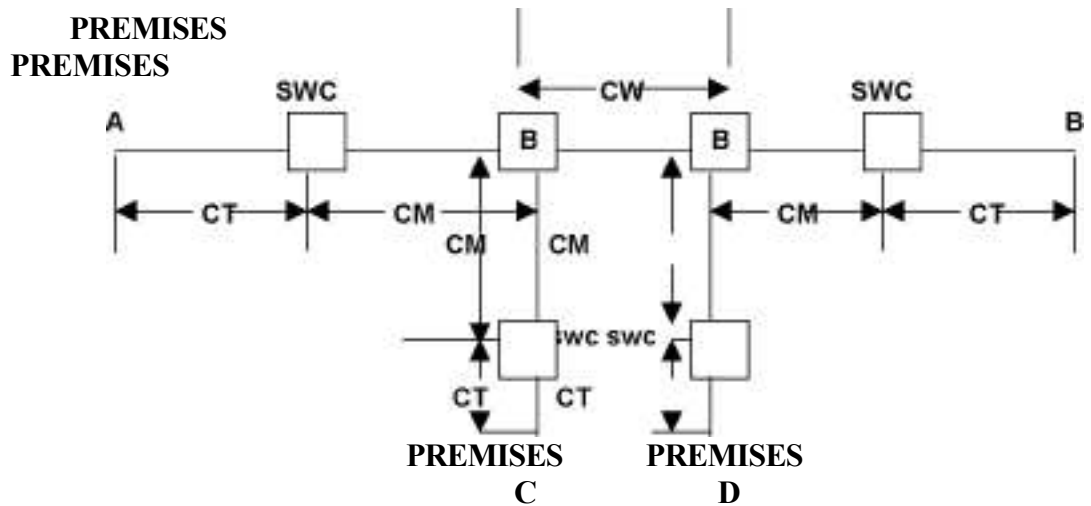

- CT - Circuit Termination
- CM - Circuit Mileage
- B - Bridging
- SWC - Serving Wire Center

Applicable rate elements are:

- Circuit Termination (4 applicable)
- Circuit Mileage (5 sections fixed-rate plus rate per mile between SWC)
- Bridging Optional features (6 applicable, i.e., each bridge port)

In addition, charges for other Optional Features and Functions may be applicable.

SPECIAL ACCESS SERVICE

I. PROVISION OF SPECIAL ACCESS SERVICE (Continued)

C. Technical Specification Package

Information pertaining to the technical specifications packages indicates the transmission parameters that are available with each package. This information is included in each individual service description section in III. through VII. following, in a matrix format with the transmission parameters listed down the left side and the packages listed across the top. Each package is identified by a code, e.g., VGC. The first two letters of the code indicate the category of Special Access Service to which the parameters are applicable. These two letter codes are shown above in parentheses following the category of Special Access Service.

The letter "C" following the two letter code indicates the technical specifications package for a customized service. A numeric or alphanumeric designation following the two letter code indicates the specific predefined package. For a customized service, the customer may select any parameters available with that category of service as long as the parameters are compatible. When appropriate, the Technical Reference which contains detailed specifications for the parameters is shown following the matrix.

All services installed after the effective date of this tariff will conform to the transmission specification standards contained in this tariff or in the following Technical References for each category of service:

| | | |
|---------------|-----|-------------------------------|
| Voice Grade | PUB | TR-NPL-000335 |
| | PUB | 41004, Table 4 |
| Program Audio | PUB | 62503 and associated Addendum |
| Video | PUB | 62504 and associated Addendum |
| Digital Data | PUB | 62507 |
| | PUB | 62310 |
| High Capacity | PUB | 64508 |
| | | 62411 |

Issued: [DATE]
Effective: [DATE]
By: Brent Kennedy
Title: President and General Manager

SPECIAL ACCESS SERVICE

I. PROVISION OF SPECIAL ACCESS SERVICE (Continued)

C. Technical Specification Package (Continued)

The Telephone Company will maintain existing transmission specifications on services installed prior to the effective date of this tariff, except that existing services with performance specifications exceeding the standards listed in this provision will be maintained at the performance levels specified in this tariff.

Customized technical specifications packages will be provided where technically feasible. If the Telephone Company determines that the requested parameter specifications are not compatible, the customer will be advised and given the opportunity to change the order.

D. Channel Interfaces

Channel interfaces at each point of termination on a two-point service may be symmetrical or asymmetrical. On a multipoint service they may also be symmetrical or asymmetrical, but communications can only be provided between compatible channel interfaces. Only certain channel interfaces are compatible. These are set forth in Section 8 following, in a combination format.

Only certain channel interface combination are available with the predefined technical specifications packages. These are delineated in the Technical References set forth in I.C. preceding. When a customized circuit is requested, all channel interface combinations available with the specified type of service are available with the customized circuit.

Issued: [DATE]
Effective: [DATE]
By: Brent Kennedy
Title: President and General Manager

SPECIAL ACCESS SERVICE

I. PROVISION OF SPECIAL ACCESS SERVICE (Continued)

E. Alternate Use

Alternate Use occurs when a service is arranged by the Telephone Company so that the customer can select different types of transmission at different times. A customer may use a service in any privately beneficial manner. However, where technical or engineering changes are required to effectuate an alternate use, the Telephone Company will make such special arrangements available on an individual case basis.

The arrangement required to transfer the service from one operation to the other (i.e., the transfer relay and control leads) will be rated and provided on an individual case basis and filed in Section 11, Specialized Service or Arrangements. The customer will pay the stated tariff rates for the Access Service rate elements for the service ordered (i.e., Circuit Terminations, Circuit Mileage [as applicable] and Optional Features and Functions [if any]).

F. Special Facilities Routing

A customer may request that the Special Access used be specially routed. The regulations, rates and charges for Special Facilities Routing are as set forth in Section 10 following.

G. Design Layout Report

At the customer request, the Telephone Company will provide the make-up of the facilities and services provided under this tariff as Special Access Service to aid the customer in designing its overall service. The information will be provided to the customer at no charge in the form of a Design Layout Report and will be reissued or updated whenever the described facilities are materially changed.

Issued: [DATE]
Effective: [DATE]
By: Brent Kennedy
Title: President and General Manager

SPECIAL ACCESS SERVICE

I. PROVISION OF SPECIAL ACCESS SERVICE (Continued)

H. Acceptance Testing

At the customer's request, the Telephone Company will cooperatively test, at the time of installation and at no additional charge, the following parameters:

1. For Voice Grade analog services, acceptance testing will include tests for loss, 3-tone slope, DC continuity, operational signaling, C-notched noise, and C-message noise as applicable according to the order for service. Voice Grade services acceptance testing will also include a balance (improved loss) test if the customer has ordered that optional feature.
2. For services other than Voice Grade, acceptance tests will include tests for the parameters applicable to the service as specified by the customer in the order for service.

In addition to the above tests, Additional Cooperative Acceptance Testing and Nonscheduled Testing, as described in Section 7, IV. following, are available at the customer's request. All test results will be made available to the customer upon request.

Issued: [DATE]
Effective: [DATE]
By: Brent Kennedy
Title: President and General Manager

SPECIAL ACCESS SERVICE

II. RATE CATEGORIES, APPLICATIONS AND REGULATIONS

This section contains the specific regulations governing the rates and charges that apply for Special Access.

A. Rate Categories

The following rate categories apply to Special Access Service:

- Circuit Terminations
- Circuit Mileage
- Optional Features and Functions
- Nonrecurring Charges

These rate categories are described in II.A.1. thru 4. following:

1. Circuit Termination

The Circuit Termination rate category provides for the communications path between a customer designated premises and the serving wire center of that premises. Included as part of the Circuit Termination is a standard channel interface arrangement which defines the technical characteristics associated with the type of facilities to which the access service is to be connected at the Point of Termination (POT) and the type of signaling capability, if any. The signaling capability itself is provided as an optional feature as set forth in 3. following. One Circuit Termination charge applies per customer designated premises at which the circuit is terminated. This charge will apply even if the customer designated premises and the serving wire center are co-located in a Telephone Company building.

Issued: [DATE]
Effective: [DATE]
By: Brent Kennedy
Title: President and General Manager

SPECIAL ACCESS SERVICE

II. RATE CATEGORIES, APPLICATIONS AND REGULATIONS (Continued)

A. Rate Categories (Continued)

2. Circuit Mileage

The Circuit Mileage rate category provides for the end office equipment and transmission facilities between serving wire centers and/or Telephone Company hubs. In addition, when Special Access is used in conjunction with Switched Access Service as set forth in Section 5, III.B.20. preceding for Combined Access Service Arrangements, and the end office serving the customer's end user premises is not capable of combining Switched and Special Access or is not a WATS Serving Office, Circuit Mileage is used to extend the Special Access Circuit to a WATS Serving Office or office capable of combining Switched and Special Access Services. The Circuit Mileage charge is composed of a flat monthly charge plus a rate per mile.

a. Fixed Rate

The fixed rate component of Circuit Mileage is applied only once per Circuit Mileage facility and is also applied when two or more customer designated premises are service by a common serving wire center (i.e., mileage is zero). When Special Access is used in conjunction with Switched Access where the customer's end user premises for the Special Access facility is served by a Telephone Company office capable of combining Switching and Special Access Service, or a WATS Serving Office, the fixed rate does not apply.

Issued: [DATE]
Effective: [DATE]
By: Brent Kennedy
Title: President and General Manager

SPECIAL ACCESS SERVICE

II. RATE CATEGORIES, APPLICATIONS AND REGULATIONS (Continued)

A. Rate Categories (Continued)

2. Circuit Mileage (Continued)

b. Per Mile Rate

The mileage to be used to determine the monthly rate for the per mile portion of Circuit Mileage is calculated on the airline distance between the serving wire centers associated with the two customer designated premises, between a serving wire center associated with a customer designated premises and a Telephone Company hub, between two Telephone Company hubs, or between a Telephone Company end office and a WATS serving office, or Telephone Company office capable of combining Switched and Special Access Services. The serving wire center associated with a customer designated premises is the serving wire center from which this customer designated premises would normally receive dial tone. The methodology for mileage calculation and serving wire center V&H coordinates are specified in NATIONAL EXCHANGE CARRIER ASSOCIATION TARIFF FCC NO. 4. Where the calculated miles include a fraction, the value is always rounded up the next full mile.

When hubs are involved, mileage is computed and rates applied separately for each section of the Circuit Mileage, (i.e., customer designated premises serving wire center to hub, hub to hub and/or hub to customer designated premises serving wire center). However, when any service is routed through a hub for purposes other than customer specified bridging or multiplexing (e.g., the Telephone Company chooses to so route for test access purposes), rates will be applied only to the distance calculated between the serving wire centers associated with the customer designated premises.

Issued: [DATE]
Effective: [DATE]
By: Brent Kennedy
Title: President and General Manager

SPECIAL ACCESS SERVICE

II. RATE CATEGORIES, APPLICATIONS AND REGULATIONS (Continued)

A. Rate Categories (Continued)

2. Circuit Mileage (Continued)

b. Per Mile Rate (Continued)

When more than one Telephone Company is involved in the provision of Special Access Service, the mileage for the per mile component of Circuit Mileage for each Telephone Company is calculated as set forth in Section 2, IV.G. preceding.

3. Optional Features and Functions

Optional Features and Functions may be added to a basic circuit service to improve its quality or utility to meet the customer's specific communications requirements. These optional features and functions are identifiable with specific equipment, and represent the end result in terms of performance characteristics which may be obtained. These characteristics may be obtained by using various combinations of equipment. Although the equipment necessary to perform a specified function may be installed at various locations along the path of the service, they will be charged for a single rate element.

Descriptions for each of the available Optional Features and Functions are set forth in III. through VII. following. Specific rate applications for multiplexing are set forth in II.D. following.

Issued: [DATE]
Effective: [DATE]
By: Brent Kennedy
Title: President and General Manager

SPECIAL ACCESS SERVICE

II. RATE CATEGORIES, APPLICATIONS AND REGULATIONS (Continued)

A. Rate Categories (Continued)

4. Nonrecurring Charge

Nonrecurring charges are one-time charges that apply for installation of Special Access Services, installation of optional features and functions, and moves and service rearrangements.

a. Installation of Service

Nonrecurring charges apply to each service installed. The nonrecurring charges for the installation of service are applied per Circuit Termination.

b. Installation of Optional Features and Functions

Nonrecurring charges apply for the installation of some of the optional features and functions available with Special Access Service. The charge applies whether the feature or function is installed coincident with the initial installation of service or at any time subsequent to the installation of the service.

The optional features for which nonrecurring charges apply are:

- Voice Grade Data Capability
- Voice Grade Telephoto Capability
- Program Audio Gain Conditioning
- Program Audio Stereo

Issued: [DATE]
Effective: [DATE]
By: Brent Kennedy
Title: President and General Manager

SPECIAL ACCESS SERVICE

II. RATE CATEGORIES, APPLICATIONS AND REGULATIONS (Continued)

A. Rate Categories (Continued)

4. Nonrecurring Charge (Continued)

c. Moves

A move involves a change in the physical location of either the customer's premises or a point of termination at the customer's premises. The charges for the move are dependent on whether the move is to a new location within the same building or to a different building.

1) Moves Within the Same Building

When the move is to a new location within the same building, the charge for the move will be an amount equal to one half of the nonrecurring (i.e., installation) charge for the service termination affected. There will be no change in the minimum period requirements.

2) Moves to a Different Building

Moves to a different building will be treated as a discontinuance and a start of service and all associated nonrecurring charges will apply. New minimum period requirements will be established for the new services. The customer will also remain responsible for satisfying all outstanding minimum period charges for the discontinued service.

Issued: [DATE]
Effective: [DATE]
By: Brent Kennedy
Title: President and General Manager

SPECIAL ACCESS SERVICE

II. RATE CATEGORIES, APPLICATIONS AND REGULATIONS (Continued)

A. Rate Categories (Continued)

4. Nonrecurring Charge (Continued)

d. Service Arrangements

Special Rearrangements are changes to existing (installed) services which may be administrative only in nature, or that involve actual physical change to the service. Changes to pending orders are set forth in Section 4, III.A. preceding.

1) A charge will not apply to administrative changes as follows:

- Change of customer name,
- Change of customer or customer's end user premises address when the change of address is not a result of a physical relocation of equipment,
- Change in billing date (name, address, or contact name or telephone number),
- Change of agency authorization,
- Change of customer circuit identification,
- Change of billing account number,
- Change of customer test line number,
- Change of customer or customer's end user contact name or telephone number, and
- Change of jurisdiction.

2) All other service rearrangement will be charged for as follows:

If the change involves the addition of other customer designated premises to an existing multipoint service, the nonrecurring charge for the Circuit Termination rate element will apply. The charge(s) will apply only for the location(s) that is being added;

Issued: [DATE]
Effective: [DATE]
By: Brent Kennedy
Title: President and General Manager

SPECIAL ACCESS SERVICE

II. RATE CATEGORIES, APPLICATIONS AND REGULATIONS (Continued)

A. Rate Categories (Continued)

4. Nonrecurring Charge (Continued)

d. Service Arrangements (Continued)

2) (Continued)

If the change involves the addition of an optional feature or function which has a separate nonrecurring charge, that nonrecurring charge will apply;

If the change involves changing the type of signaling on a Voice Grade service, a charge equal to the Voice Grade Circuit Termination rate element nonrecurring charge will apply. The charge will apply per service termination affected;

For all other changes, including the addition of optional feature or function without a separate nonrecurring charge, a charge equal to a Circuit Termination rate element nonrecurring charge will apply. Only one such charge will apply per service, per change.

B. Minimum Periods

The minimum service period for all services except part-time and occasional Video and Program Audio services is one month. The minimum service period for part-time Video and Program Audio Services is one day even though the service will be provided only for the duration of the event specified on the order (e.g., one-half hour, two hours, five hours, etc.).

Issued: [DATE]
Effective: [DATE]
By: Brent Kennedy
Title: President and General Manager

SPECIAL ACCESS SERVICE

II. RATE CATEGORIES, APPLICATIONS AND REGULATIONS (Continued)

C. Application of Daily and Monthly Rates

1. Daily Rates

Daily rates are recurring rates that apply to each 24-hour period or fraction thereof that a Video or Program Audio Special Access Service provided for part-time or occasional use. For purposes of applying daily rates, the 24-hour period is not limited to a calendar day.

Part-time Program Audio or Video Service ordered on one Access Service Request and provided within a consecutive 30-day period will be charged the daily rate, not to exceed an amount equal to the monthly rate. For each subsequent day or part day, a charge equal to 1/30th of the monthly rate shall apply.

2. Monthly Rates

Monthly rates are flat recurring rates that apply each month or fraction thereof that a Special Access Service is provided. For billing purposes, each month is considered to have 30 days.

Issued: [DATE]
Effective: [DATE]
By: Brent Kennedy
Title: President and General Manager

SPECIAL ACCESS SERVICE

II. RATE CATEGORIES, APPLICATIONS AND REGULATIONS (Continued)

D. Facility Hubs and Multiplexing

A customer has the option of ordering Voice Grade facilities or High Capacity facilities (i.e., Group, Supergroup, Mastergroup, DS1, DS1C, DS2, DS3 or DS4) to a facility hub for multiplexing to individual services of a lower capacity or bandwidth (e.g., Telegraph, Voice, Program Audio, etc.). Additionally, the customer may specify optional features for the individual circuits derived from the facility to further tailor the circuit to meet specific communications requirements.

Some of the types of multiplexing available include the following:

- from higher to lower bit rate
- from higher to lower bandwidth
- from digital to voice frequency circuits

A hub is a Telephone Company designated wire center at which multiplexing functions are performed.

Different locations may be designated as hubs for different facility capacities, (i.e., multiplexing from digital to digital may occur at one location while multiplexing from digital to analog may occur at a different location). When placing an Access Service Request the customer will specify the desired hub. The NATIONAL EXCHANGE CARRIER ASSOCIATION TARIFF FCC NO. 4 identifies serving wire center, hub locations and the type of multiplexing functions available.

Point to point services may be provided on circuits of these facilities to a hub. The transmission performance for the point to point service provided between the customer designated premises will be that of the lower capacity or bit rate.

Issued: [DATE]
Effective: [DATE]
By: Brent Kennedy
Title: President and General Manager

SPECIAL ACCESS SERVICE

II. RATE CATEGORIES, APPLICATIONS AND REGULATIONS (Continued)

D. Facility Hubs and Multiplexing (Continued)

The Telephone Company will commence billing the monthly rate for the facility to the hub on the date specified by the customer on the Access Service Request. The customer will be billed for a High Capacity or Voice Grade Circuit Termination, Circuit Mileage and the multiplexer for the service at the time the facility is installed. Individual services utilizing these facilities may be installed coincident with the installation of the facility to the hub or may be ordered and/or installed at a later day, at the option of the customer. Individual service rates (by service type) will apply for a Circuit Termination and additional Circuit Mileage (as required) for each channelized service. These will be billed to the customer as each individual service is installed.

Cascading multiplexing occurs when a high capacity circuit is de-multiplexed to provide circuits with a lesser capacity and one of the lesser capacity circuits is further de-multiplexed. When cascading multiplexing is performed, whether in the same or a different hub, a charge for the additional multiplexing unit also applies. When cascading multiplexing is performed at different hubbing locations, Circuit Mileage charges also apply between the hubs.

Although not requiring multiplexing, the Telephone Company will designate certain hubs for Video and Program Audio Services. Full-time service will be provided between a customer designated premises and a hub and billed accordingly at the monthly rates set forth in IV.E. and V.D. for a Circuit Termination, and Circuit Mileage and optional Features and Functions as applicable. The customer may order part-time and occasional Program Audio or Video services as needed between the hub and a second customer designated premises. The rate elements required to provide the part-time or occasional service (i.e., Circuit Termination, and Circuit Mileage and Optional Features as applicable) will be billed at daily rates for the duration of the service requested.

Issued: [DATE]
Effective: [DATE]
By: Brent Kennedy
Title: President and General Manager

SPECIAL ACCESS SERVICE

II. RATE CATEGORIES, APPLICATIONS AND REGULATIONS (Continued)

E. Shared Use Digital High Capacity Services

Shared use refers to a rate application applicable only when the customer orders High Capacity facilities between a customer designated premises and a Telephone Company hub where the Telephone Company performs multiplexing/de-multiplexing functions and the same customer then orders the derived circuits as Special and Switched Access Services.

The facility will be ordered, provided and rated as Special Access Service (i.e., Circuit Termination, Circuit Mileage, as appropriate, and Multiplexing Arrangement). The nonrecurring charge that applies when the shared use facility is installed will be the nonrecurring charge associated with the appropriate Special Access High Capacity Circuit Termination. Rating as Special Access will continue until such time as the customer chooses to use a portion of the available capacity for Switched Access Service. Individual service (i.e., Switched or Special Access) nonrecurring charges will not apply to the individual circuits of the shared use facility.

As each individual circuit is activated for Switched Access Service, the High Capacity Special Access Circuit Termination and Circuit Mileage rates will be reduced accordingly (e.g., 1 /24th for a DS1 service, etc.). Switched Access Service rates and charges, as set forth in Section 4, preceding, will apply for each circuit of the shared use facility that is used to provide a Switched Access Service.

The customer must place an order for each individual Switched or Special Access Service utilizing the Shared Use Facilities and specify the circuit assignment for each such service.

Issued: [DATE]
Effective: [DATE]
By: Brent Kennedy
Title: President and General Manager

SPECIAL ACCESS SERVICE

II. RATE CATEGORIES, APPLICATIONS AND REGULATIONS (Continued)

E. Shared Use Digital High Capacity Services (Continued)

When Special Access Service is provided utilizing a circuit of the shared use facility to a hub, High Capacity rates and charges will apply for the facility to the hub, as set forth preceding, and individual service rates and charges will apply from the hub to the customer designated premises. The rates and charges that will apply to the portion from the hub to the customer designated premises will be dependent on the specific type of Special Access Service that is provided (e.g., Voice Grade, Telegraph, etc.). The applicable rates and charges will include a Circuit Termination and Circuit Mileage, if applicable. Rates and charges for optional features and functions associated with the service, if any, will apply for the appropriate circuit type.

Issued: [DATE]
Effective: [DATE]
By: Brent Kennedy
Title: President and General Manager

SPECIAL ACCESS SERVICE

III. VOICE GRADE SERVICE

A. Basic Circuit Description

A Voice Grade Circuit is a circuit which provides voice frequency transmission capability in the nominal frequency range 300 to 3000 Hz and may be terminated two-wire or four-wire. Effective 2-wire and 4-wire circuits are available as an Optional Feature and Function.

Voice Grade circuits are provided between customer designated premises or between a customer designated premises and a Telephone Company hub.

Voice Grade Service may be ordered in conjunction with Switched Access services as set forth in Section 5, III.B.20. preceding to provide access for a customer's communication service (e.g., WATS, 800, or WATS-type service). When the customer orders the Combined Access Service Arrangement, Voice Grade Circuits provide voice frequency transmission capability between an end user premises and Telephone Company offices capable of combining Special and Switched Access services or between an end user premises and a WATS Serving Office (WSO). All applicable Special Access rates and charges apply (including Optional Features and Functions charges). Technical Specifications and Optional Features and Functions available with this arrangement are indicated under Package VG-CA in III.B and III.D. following.

Issued: [DATE]
Effective: [DATE]
By: Brent Kennedy
Title: President and General Manager

SPECIAL ACCESS SERVICE

III. VOICE GRADE SERVICE (Continued)

B. Technical Specifications Packages

| Parameter | Package VG | | | | | | | | | | | | | CA |
|------------------|------------|---|---|---|---|---|---|---|---|---|----|----|----|----|
| | C* | 1 | 2 | 3 | 4 | 5 | 6 | 7 | 8 | 9 | 10 | 11 | 12 | |
| Attenuation | | | | | | | | | | | | | | |
| Distortion | X | X | X | X | X | X | X | X | X | X | X | X | X | X |
| C-Message | | | | | | | | | | | | | | |
| Noise | X | X | X | X | X | X | X | X | X | X | X | X | X | X |
| Echo Control | X | X | X | X | X | X | | X | X | X | | X | X | X |
| Envelope Delay | | | | | | | | | | | | | | |
| Distortion | X | | | | | | X | X | X | X | X | X | X | X |
| Impulse Noise | | | | | | X | X | X | X | X | X | X | X | X |
| Intermodulation | | | | | | | | | | | | | | |
| Distortion | X | | | | | | X | X | X | X | X | X | X | X |
| Loss Deviation | X | X | X | X | X | X | X | X | X | X | X | X | X | X |
| Phase Hits, Gain | | | | | | | | | | | | | | |
| Hits, & | | | | | | | | | | | | | | |
| Dropouts | X | | | | | | | | | | | | | |
| Phase Jitter | X | | | | | | X | X | X | X | X | X | X | X |
| Return Loss | | | | | | | | | | | | | | X |
| Signal-to-C | | | | | | | | | | | | | | |
| Message Noise | | | | | X | | | | | | | | | |
| Signal-to-C | | | | | | | | | | | | | | |
| Notch Noise | X | | | | | X | X | X | X | X | X | X | X | X |

The technical specifications for these parameters (except for dropouts, gain hits, and phase hits) are delineated in Technical Reference TR-NPL-000335 and associated Addendum. The technical specifications for dropouts, phase hits, and gain hits are delineated in Technical Reference PUB 41004, Table 4.

The desired The desired parameters are selected by the customer from the list of available parameters.

Issued: [DATE]
 Effective: [DATE]
 By: Brent Kennedy
 Title: President and General Manager

SPECIAL ACCESS SERVICE

III. VOICE GRADE SERVICE (Continued)

C. Channel Interfaces

The following channel interfaces for Voice Grade service do not require signaling capability: AH, DA, DB, DD, DE, DS, NO, PR and TF.

The following channel interfaces for Voice Grade service require signaling capability: AB, AC, CT, DX, DY, EA, EB, EC, EX, GO, GS, LA, LB, LC, LO, LR, LS, RV and SF.

Compatible channel interfaces are set forth in Section 8 following.

D. Optional Features and Functions

1. Central Office Bridging Capability
 - a. Voice Bridging (two-wire or four-wire)
 - b. Data Bridging (two-wire or four-wire)
 - c. Telephoto Bridging (two-wire and four-wire)
 - d. Dataphone Select-A-Station Bridging, with a sequential arrangement ports or addressable arrangement ports
 - e. Telemetry and Alarm Bridging, Split Band-Active Bridging, Passive Bridging, Summation-Active Bridging

2. Central Office Multiplexing

Voice to Telegraph Grade: An arrangement that converts a Voice Grade circuit to Telegraph Grade circuits using frequency division multiplexing.

Issued: [DATE]
Effective: [DATE]
By: Brent Kennedy
Title: President and General Manager

SPECIAL ACCESS SERVICE

III. VOICE GRADE SERVICE (Continued)

D. Optional Features and Functions (Continued)

3. Conditioning

Conditioning provides more specific transmission characteristics for Voice Grade services. C-Type conditioning controls attenuation distortion and envelope delay distortion. Sealing Current helps maintain continuity on dry metallic loops.

For two-point services, the parameters apply to each service. For multipoint services, the parameters apply to each mid link or end link. C-Type conditioning Data Capability may be combined on the same service.

a. C-Type Conditioning

C-Type Conditioning is provided for the additional control of attenuation distortion and envelope delay distortion on data services. The attenuation distortion and envelope delay distortion specifications for C-Type Conditioning are:

| Attenuation Distortion (Frequency Response) <u>Relative to 1004 Hz</u> | <u>Envelope Delay Distortion</u> | |
|--|--------------------------------------|---------------------------------|
| Frequency Variation <u>Range (Hz) (dB)</u> | Frequency <u>Range (Hz)</u> | Variation (micro- second) |
| 400-2800 -1.0 to+2.0-1.0 to+3.0 | 1000-2600 | 100 |
| 300-3000 2.0 to +6.0 | 800-2600 | 200 |
| 30000-3200 | 600-2600 | 300 |
| | 500-2800 | 600 |
| | | 3000 |

Issued: [DATE]
Effective: [DATE]
By: Brent Kennedy
Title: President and General Manager

SPECIAL ACCESS SERVICE

III. VOICE GRADE SERVICE (Continued)

D. Optional Features and Functions (Continued)

3. Conditioning (Continued)

b. Sealing Current

Sealing Current Conditioning is provided to help maintain continuity' on dry metallic loops. It is usually associated with four-wire DA nor NO type channel interfaces.

4. Customer Specified Premises Receive Level

This option allows the customer to specify the receive level at the Point of Termination. This level must be within a specific range on effective four-wire transmission. The ranges are delineated in Technical Reference TR-NPL-000335.

5. Improved Return Loss

a. On Effective Four-Wire Transmission at Four-Wire Point of Termination (applicable to each two-wire port): Provides for a fixed 600 ohm impedance, variable level range and simplex reversal. Telephone Company equipment is required at the customer's premises where this option is ordered. The Improved Return Loss parameters are delineated in Technical Reference TR-NPL-000335.

b. On Effective Two-Wire Transmission at Two-Wire Point of Termination Provides for more stringent Echo Control specifications. In order for this option to be applicable, the transmission path must be four-wire at one POT and two-wire at the other POT. Placement of Telephone Company equipment may be required at the customer's premises with the two-wire POT. The Improved Return Loss parameters are delineated in Technical Reference TR-NPL-000335.

Issued: [DATE]
Effective: [DATE]
By: Brent Kennedy
Title: President and General Manager

SPECIAL ACCESS SERVICE

III. VOICE GRADE SERVICE (Continued)

D. Optional Features and Functions (Continued)

6. Data Capability

Data Capability provides transmission characteristics suitable for data communications. Specifically, Data Capability provides for the control of Signal to C-Notched Noise Ratio and intermodulation distortion. It is available for two-point service or multipoint services.

The signal to C-Notched Noise Ratio and intermodulation distortion parameters for Data Capability are:

Signal to C-Notched Noise Ratio is greater than or equal to 32dB

Intermodulation distortion

Signal to second order modulation products (R2) is greater than or equal to 38dB

Signal to third order modulation products (R3) is greater than or equal to 42 dB

When a service equipped with Data Capability is used for voice communications, the quality of the voice transmission may not be satisfactory.

Issued: [DATE]
Effective: [DATE]
By: Brent Kennedy
Title: President and General Manager

SPECIAL ACCESS SERVICE

III. VOICE GRADE SERVICE (Continued)

D. Optional Features and Functions (Continued)

7. Telephoto Capability

Telephoto Capability provides transmission characteristics suitable for telephotographic communications. Specifically, Telephoto Capability is provided for the control of attenuation distortion and envelope delay distortion of telephotographic services. The attenuation distortion and envelope delay distortion parameters for Telephoto Capability are:

| <u>Attenuation Distortion</u> (1004Hz Reference) | | <u>Envelope Delay Distortion</u> | |
|---|-----------------------|----------------------------------|------------------------|
| <u>Frequency Range (Hz)</u> | <u>Variation (dB)</u> | <u>Frequency Range (Hz)</u> | <u>Variation (mcs)</u> |
| 500-3000 | -0.5 to +1.5 | 1000-2600 | 110 |
| 300-3200 | -1.0 to +2.5 | 800-2800 | 180 |

8. Signaling Capability

Signaling Capability provides for the ability to transmit signals from one customer premises to another customer premises on the same service.

9. Selective Signaling Arrangement

An arrangement that permits code selective ringing for up to ten codes on a multipoint service.

Issued: [DATE]
Effective: [DATE]
By: Brent Kennedy
Title: President and General Manager

SPECIAL ACCESS SERVICE

III. VOICE GRADE SERVICE (Continued)

D. Optional Features and Functions (Continued)

10. Transfer Arrangement

An arrangement that affords the customer an additional measure of flexibility in the use of their access circuits. The arrangement can be utilized to transfer a leg of a Special Access Service to another circuit that terminates in either the same or a different customer premises. A key activated or dial-up control service if required to operate the transfer arrangement. A spare circuit, if required, is not included as part of the option.

11. Four-Wire/Two-Wire Conversions

The term “Effective 2-Wire” denotes a condition which permits the simultaneous transmission in both directions over a channel, but it is not possible to insure independent information transmission in both directions. Effective 2-wire channels may be terminated with 2-wire or 4-wire interfaces.

The term “Effective 4-Wire” denotes a condition which permits the simultaneous independent transmission of information in both directions over a channel. The method of implementing effective 4-wire transmission is at the discretion of the Telephone Company (physical, time domain, frequency-domain separation or echo cancellation techniques). Effective 4-wire channels may be terminated with a 2-wire interface at the customer’s premises. however, when terminated 2-wire, simultaneous independent transmission cannot be supported because the two-wire interface combines the transmission paths into a single path.

When a customer requests that an effective four-wire circuit be terminated with a two-wire circuit interface at the customer designated premises, a four-wire to two-wire conversion is required. The customer will be charged the 4-wire Circuit Termination rate when an effective four-wire is specified in the customer’s order. The rate for the conversion is included as part of the basic Circuit Termination rate.

Issued: [DATE]
Effective: [DATE]
By: Brent Kennedy
Title: President and General Manager

SPECIAL ACCESS SERVICE

III. VOICE GRADE SERVICE (Continued)

D. Optional Features and Functions (Continued)

The following table shows the technical specifications packages with which the optional features and functions are available.

| | Available with Technical Specifications Package VG- | | | | | | | | | | | | | CA |
|---|---|---|---|---|---|---|---|---|---|---|----|----|----|----|
| | C | 1 | 2 | 3 | 4 | 5 | 6 | 7 | 8 | 9 | 10 | 11 | 12 | |
| C-Type Conditioning | X | | | | | X | X | X | X | X | X | | | |
| Central Office Bridging Capability | X | | X | | | X | X | | | X | X | X | | |
| Central Office Multiplexing | X | | | | | | X | | | | | | | |
| Customer Specified Premises Receive Level | X | | X | X | | | | X | X | X | | | | |
| Data Capability | X | | | | | | X | X | | X | | | | |
| Improved Return Loss - For Effective Four-Wire Transmission | X | X | X | X | X | X | X | X | X | X | X | X | X | X |
| - For Effective Two-Wire Transmission | X | | X | X | | | | X | | | | | X | |
| Sealing Current Conditioning | X | | | | | | X | | | | | | | |
| Selective Signaling Arrangement | X | | X | | | X | X | | | X | X | X | | |
| Signaling Capability | X | X | X | X | | | | X | X | X | | | | X |
| Transfer Arrangement | X | X | X | X | X | X | X | X | X | X | X | X | X | |

Issued: [DATE]
 Effective: [DATE]
 By: Brent Kennedy
 Title: President and General Manager

SPECIAL ACCESS SERVICE

III. VOICE GRADE SERVICE (Continued)

E. Rates and Charges [See Section 14, IV.]

| | <u>Monthly Rates</u> | <u>Nonrecurring Charge</u> |
|--|-------------------------|----------------------------|
| 1. Circuit Termination - Per Point of Termination - Two-wire - Four-wire | [See Section 14, IV.A.] | |
| 2. Circuit Mileage - Fixed - Two-wire - Per mile - Two/Four-wire | [See Section 14, IV.B.] | |

Issued: [DATE]
Effective: [DATE]
By: Brent Kennedy
Title: President and General Manager

SPECIAL ACCESS SERVICE

III. VOICE GRADE SERVICE (Continued)

E. Rates and Charges [See Section 14, IV.] (Continued)

3. Optional Features and Functions [See Section 14, IV.C.]
Rates and charges for the Optional Features and Functions of Voice Grade Service listed in this section apply to all jurisdictions.

| | <u>Monthly Rates</u> | <u>Nonrecurring Charge</u> |
|---|----------------------|----------------------------|
| a. Bridging | | |
| 1) <u>Voice Bridging</u> | | |
| - Per port | | |
| - Two-wire | | |
| 2) <u>Data Bridging</u> | | |
| - Per port | | |
| - Two-wire | | |
| 3) <u>Telephoto Bridging</u> | | |
| - Per port | | |
| - Two-wire | | |
| 4) <u>DATAPHONE Select-A-Station Bridging</u> | | |
| Sequential Arrangement Ports | | |
| - Per Circuit Connected | | |
| - Two-wire | | |
| - Four-wire | | |
| Addressable Arrangement Ports | | |
| - Per Circuit Connected | | |
| - Two-wire | | |
| - Four-wire | | |

Issued: [DATE]
Effective: [DATE]
By: Brent Kennedy
Title: President and General Manager

SPECIAL ACCESS SERVICE

III. VOICE GRADE SERVICE (Continued)

E. Rates and Charges [See Section 14, IV.] (Continued)

3. Optional Features and Functions [See Section 14, IV.C.]
(Continued)

a. Bridging (Continued)

Monthly Rates Nonrecurring
Charge

[See Section 14, IV.C.1.]

- 5) Telemetry and Alarm Bridging
Active Bridging Circuit Connections
- Per Circuit Connected
- Split Band

- Passive Bridging Circuit Connections
- Per Circuit Connected

- b. Conditioning [See Section 14, IV.C.2.]
- Per Point of Termination
- C-Type

- c. Improved Return Loss for [See Section 14, IV.C.3.]
Effective Four-wire Transmission
- Per Point Termination
- Two-wire

- Four-wire

- d. Customer Specified
Receive Level [See Section 14, IV.C.4.]
- Per Two-site Point of Termination

Issued: [DATE]
Effective: [DATE]
By: Brent Kennedy
Title: President and General Manager

SPECIAL ACCESS SERVICE

III. VOICE GRADE SERVICE (Continued)

E. Rates and Charges [See Section 14, IV.] (Continued)

**3. Optional Features and Functions [See Section 14, IV.]
(Continued)**

| | <u>Monthly Rates</u> | <u>Nonrecurring Charge</u> |
|--|---|--------------------------------|
| e. Multiplexing Voice to Telegraph Grade - Per Arrangement | [See Section 14, IV.C.5.] | |
| f. Data Capability - Per Point of Termination | [See Section 14, IV.C.6.] | |
| g. Telephoto Capability - Per Point of Termination | [See Section 14, IV.C.7.] | |
| h. Signaling Capability - Per Point of Termination - In lieu of ++, substitute appropriate two digit code from following list to specify type of signaling: | [See Section 14, IV.C.8.] AB, AC, CT, DX, CY, EA, EB, EC, EX, GO, GS LA, LB, LC, LO, LR, LS, RV, SF | |

Issued: [DATE]
Effective: [DATE]
By: Brent Kennedy
Title: President and General Manager

SPECIAL ACCESS SERVICE

III. VOICE GRADE SERVICE (Continued)

E. Rates and Charges [See Section 14, IV.] (Continued)

3. Optional Features and Functions [See Section 14, IV.]
(Continued)

| | <u>Monthly</u> <u>Rates</u> | <u>Nonrecurring</u> <u>Charge</u> |
|--|--------------------------------|--------------------------------------|
|--|--------------------------------|--------------------------------------|

| | | |
|----|------------------------------------|---------------------------|
| i. | Selective Signaling Arrangement | [See Section 14, IV.C.9.] |
| | - Per Arrangement | |

| | | |
|----|---|---------------------------|
| j. | Transfer Arrangement | [See Section 14, IV.C.9.] |
| | (Key Activated* or Dial Up**) | |
| | - Per Four Port Arrangement, including control circuit termination*** | |
| | - Per Five Port Arrangement including control circuit termination*** | |

* The key activated control circuit is rated as a Circuit Termination Circuit Mileage, if applicable.

** The Dial-Up option requires the customer to purchase the Controller Arrangement from Section 12 following.

*** An additional Circuit Termination charge will apply whenever a spare circuit is configured as a leg to the customer's premises. Additional circuit mileage charges will apply when the transfer arrangement is not located in the customer premises service wire center.

Issued: [DATE]
Effective: [DATE]
By: Brent Kennedy
Title: President and General Manager

SPECIAL ACCESS SERVICE

IV. PROGRAM AUDIO SERVICE

A. Basic Circuit Description

A Program Audio circuit is a circuit measured in Hz for the transmission of a complex signal voltage. The actual bandwidth is a function of the channel interface selected by the customer. The nominal frequency bandwidths are from 50 to 15000 Hz, from 200 to 3500 Hz, from 100 to 5000 Hz or from 50 to 8000 Hz. Only one-way transmission is provided. Program Audio circuits are provided between customer designated premises or between a customer designated premises and a Telephone Company hub.

B. Technical Specifications

| | Package | | | | AP- |
|---------------------------|---------|---|---|---|-----|
| | C* | 1 | 2 | 3 | 4 |
| <u>Parameters</u> | | | | | |
| Actual Measured Loss | X | X | X | X | X |
| Amplitude Tracking | X | | | | |
| Crosstalk | X | X | X | X | X |
| Distortion Tracking | X | | | | |
| Gain/Frequency Distortion | X | X | X | X | X |
| Group Delay | X | | | | |
| Noise | X | X | X | X | X |
| Phase Tracking | X | | | | |
| Short-Term Gain Stability | X | | | | |
| Short-Term Loss | X | | | | |
| Total Distortion | X | X | X | X | X |

The technical specifications are delineated in Technical Reference PUB 62503 and associated Addendum.

* The desired parameters are selected by the customer from the list of available parameters.

Issued: [DATE]
 Effective: [DATE]
 By: Brent Kennedy
 Title: President and General Manager

SPECIAL ACCESS SERVICE

IV. PROGRAM AUDIO SERVICE (Continued)

C. Channel Interfaces

The following channel interfaces (CIs) define the bandwidths that are available for a Program Audio circuit.

| CI | <u>Bandwidth</u> |
|------|---------------------------------------|
| PG-1 | Nominal frequency from 50 to 15000 Hz |
| PG-3 | Nominal frequency from 200 to 3500 Hz |
| PG-5 | Nominal frequency from 100 to 5000 Hz |
| PG-8 | Nominal frequency from 50 to 8000 Hz |

Compatible channel interfaces are set forth in Section 8 following.

D. Optional Features and Functions

1. Central Office Bridging Capability

Distribution Amplifier

2. Gain Conditioning

Control of 1004 Hz AML a initiation of service $\text{OdB} \pm 0.5 \text{ dB}$.

3. Stereo

Provision of a pair of gain/phase equalized channels for stereo applications. (Additional AP channel must be ordered separately).

The following table shows the technical specifications packages with which the optional features and functions are available.

| | <u>Available with Technical Specifications Package AP-</u> | | | | |
|------------------------------------|--|---|---|---|---|
| | C | 1 | 2 | 3 | 4 |
| Central Office Bridging Capability | X | X | X | X | X |
| Gain Conditioning | X | X | X | X | X |
| Stereo | X | | | | X |

Issued: [DATE]
 Effective: [DATE]
 By: Brent Kennedy
 Title: President and General Manager

SPECIAL ACCESS SERVICE

IV. PROGRAM AUDIO SERVICE (Continued)

E. Rates and Charges [See Section 14, V.5]

| | <u>Monthly Rates</u> | <u>Nonrecurring Charge</u> |
|----------------------------|--------------------------|--------------------------------|
| 1. Circuit Termination | | [See Section 14, V.A.] |
| - Per Point of Termination | | |
| -200 to 3500 Hz | | |
| -100 to 5000 Hz | | |
| -50 to 8000 Hz | | |
| -50 to 15000 Hz | | |
| | | <u>Daily Rates*</u> |
| -200 to 3500 Hz | | |
| -100 to 5000 Hz | | |
| -50 to 8000 Hz | | |
| -50 to 15000 Hz | | |

* Daily Rates will be topped and maximum rates derived as set forth in II.C.1. preceding.

Issued: [DATE]
Effective: [DATE]
By: Brent Kennedy
Title: President and General Manager

SPECIAL ACCESS SERVICE

IV. PROGRAM AUDIO SERVICE (Continued)

E. Rates and Charges [See Section 14, V.] (Continued)

Monthly Rates

[See Section 14, V.]

2. Circuit Mileage
- Fixed
 - 200 to 3500 Hz
 - 100 to 5000 Hz
 - 50 to 8000 Hz
 - 50 to 15000 Hz

- Per Mile
 - 200 to 3500 Hz
 - 100 to 500 Hz
 - 50 to 8000 Hz
 - 50 to 15000 Hz

- Circuit Mileage
- Fixed

Daily Rates*

- 200 to 3500 Hz
- 100 to 5000 Hz
- 50 to 8000 Hz
- 50 to 15000

* Daily Rates will be topped and maximum rates derived as set forth in II.C.1. preceding.

Issued: [DATE]
Effective: [DATE]
By: Brent Kennedy
Title: President and General Manager

SPECIAL ACCESS SERVICE

IV. PROGRAM AUDIO SERVICE (Continued)

F. Rates and Charges [See Section 14, V.] (Continued)

Daily Rates*

[See Section 14, V.B.]

2. Circuit Mileage (Continued)

-200 to 3500 Hz

-100 to 5000 Hz

-50 to 8000 Hz

-50 to 15000 Hz

[See Section 14, V.C.]

3. Optional Features and Functions

Rates and charges for the Optional Features and Functions of Program Audio Service listed in this section apply to all jurisdictions.

| | <u>Monthly</u> | <u>Daily</u> | <u>Nonrecurring</u> |
|--|----------------|--------------|----------------------|
| | <u>Rates</u> | <u>Rates</u> | <u>Monthly Daily</u> |

- Bridging, Distribution
Amplifier
- Per Port

- Gain Conditioning
- Per Service

- Stereo
- Per Service

* Daily Rates will be topped and maximum rates derived as set forth in II.C.1. preceding.

Issued: [DATE]
Effective: [DATE]
By: Brent Kennedy
Title: President and General Manager

SPECIAL ACCESS SERVICE

V. VIDEO SERVICE

A. Basic Circuit Description

A Video circuit is a circuit with one-way transmission capability for a standard 525 line/60 field monochrome, or National Television Systems Committee color video signal and one or two associated 5 or 15 kHz audio signal(s). The bandwidth for a video circuit is either 30 Hz to 4.5 MHz or 30 Hz to 6.6 MHz. The associated audio signal(s) may be either duplexed or provided as one or two separate circuits. The provision and the bandwidth of the associated audio signal(s) is a function of the channel interface selected by the customer. Video circuits are provided between customer designated premises or between a customer designated premises and a Telephone Company hub.

B. Technical Specifications Packages

| <u>Parameter</u> | <u>Package TV-</u> | | |
|--|--------------------|----------|----------|
| | <u>C</u> | <u>1</u> | <u>2</u> |
| Amplitude vs. Frequency Response | X | | |
| Chrominance/Luminance Inequalities | | | |
| Gain | X | X | X |
| Delay Chrominance/Luminance | X | X | X |
| Intermodulation | X | | |
| Chrominance Nonlinear Gain | X | | |
| Chrominance Nonlinear Phase | X | | |
| Crosstalk | X | | |
| Differential Gain | X | X | X |
| Differential Phase | X | X | X |
| Dynamic Gain (picture and sync signal) | X | X | X |
| Field-Time Distortion | X | X | X |
| Gain/Frequency Distortion | X | X | X |
| Gain Stability | X | X | X |
| Insertion Gain | X | X | X |
| Line-Time Distortion | | | |
| Long-Term Distortion | | | |

* The desired parameters are selected by the customer from the list of available parameters.

Issued: [DATE]
 Effective: [DATE]
 By: Brent Kennedy
 Title: President and General Manager

SPECIAL ACCESS SERVICE

V. VIDEO SERVICE (Continued)

B. Technical Specifications Packages (Continued)

| <u>Parameter</u> | <u>Package TV-</u> | | |
|---|--------------------|----------|----------|
| | <u>C</u> | <u>1</u> | <u>2</u> |
| Luminance Nonlinearity | X | | |
| Luminance Signal/CCIR Weighted Noise | X | X | X |
| Short-Time Distortion 2 T Pulse | X | X | X |
| T-Bar Ringing | X | X | X |
| Signal/15 kHz Flat Weighted Noise | X | X | X |
| Signal/Low Frequency Noise | X | | |
| Stereo Gain Difference | X | X | |
| Stereo Phase Difference | X | X | |
| Total Harmonic Distortion | X | X | X |
| Transient Sync Signal Non-Linearity | X | | |
| Video/Audio Delay Difference | X | | |

The technical specifications are delineated in Technical Reference PUB 620504 and associated Addendum.

C. Channel Interfaces

The following channel interfaces (CIs) define the bandwidth and the provision of the audio signal(s) associated with a Video circuit:

| <u>CI</u> | <u>Audio Bandwidth</u> | <u>Provision</u> |
|-----------|----------------------------|----------------------|
| 2TV6-1 | 15kHz | 1 Channel, duplexed |
| 2TV6-2 | 15kHz | s Channels, duplexed |
| 2TV7-1 | 15kHz | 1 Channel, duplexed |

* The desired parameters are selected by the customer from the list of available parameters.

Issued: [DATE]
 Effective: [DATE]
 By: Brent Kennedy
 Title: President and General Manager

SPECIAL ACCESS SERVICE

V. VIDEO SERVICE (Continued)

C. Channel Interfaces (Continued)

| CI | Audio Bandwidth | Provision |
|---------|--------------------|----------------------|
| 2TV7-2 | 15kHz | 2 Channels, duplexed |
| 4TV6-5 | 5kHz | 1 Channel, duplexed |
| 4TV6-15 | 15kHz | 1 Channel, separate |
| 4TV-5 | 5kHz | 1 Channel, separate |
| 4TV7-15 | 15kHz | 1 Channel, separate |
| 6TV6-6 | 5kHz | 2 Channels, separate |
| 6TV6-15 | 15kHz | 2 Channels, separate |
| 6TV7-5 | 5kHz | 2 Channels, separate |
| 6TV7-15 | 15kHz | 2 Channels, separate |

Compatible channel interfaces are set forth in Section 8 following.

Issued: [DATE]
Effective: [DATE]
By: Brent Kennedy
Title: President and General Manager

SPECIAL ACCESS SERVICE

V. VIDEO SERVICE (Continued)

D. Rates and Charges [See Section 14, VI.A.]

1. Circuit Termination
 - Per Point of Termination

Monthly Rates and Nonrecurring charges for all jurisdictions will be determined on an Individual Case Basis.

Available frequency bandwidths format is as follows:

Frequency
Bandwidths

- TV – 1 or 2
- 4TV – 5
- 6TV – 5
- TV – 15

Issued: [DATE]
Effective: [DATE]
By: Brent Kennedy
Title: President and General Manager

SPECIAL ACCESS SERVICE

V. VIDEO SERVICE (Continued)

D. Rates and Charges (Continued) [See Section 14, VI.B.]

2. Circuit Mileage

Fixed and Per Mile Monthly Rates for all jurisdictions will be determined on an Individual Case Basis.

Available mileage bands format is as follows:

Mileage
Bands
Over 0 to 4
0
Over 4 to 8
Over 8 to 25
Over 25 to 50
Over 50

Issued: [DATE]
Effective: [DATE]
By: Brent Kennedy
Title: President and General Manager

SPECIAL ACCESS SERVICE

VI. DIGITAL DATA SERVICE

A. Basic Circuit Description

A Digital Data circuit is a circuit for duplex four-wire transmission of synchronous serial data at the rate of 2.4, 4.8, 9.6 or 56 Kbps. The actual bit rate is a function of the channel interface selected by the customer. The circuit provides a synchronous service with timing provided by the Telephone Company through the Telephone Company's facilities to the customer in the received bit stream. Digital Data circuits are only available via Telephone Company designated hubs and are provided between customer designated premises or between a customer designated premises and a Telephone Company hub.

The customer may provide the Channel Service Unit-type equipment or other Network Channel Terminating Equipment associated with the Digital Data circuit at the customer premises. The interim program for interconnection of such equipment is set forth in Technical Reference PUB AS No. 1.

B. Technical Specifications Packages

| <u>Parameter</u> | <u>Package DA</u> | | | |
|--------------------|-------------------|---|---|---|
| | 1 | 2 | 3 | 4 |
| Error-Free Seconds | X | X | X | X |

The Telephone Company will provide a circuit capable of meeting a monthly average performance equal to or greater than 99.875% error-free seconds while the circuit is in service, if it is measured through a CSU equivalent which is designated, manufactured, and maintained to conform with the specifications contained in Technical Reference PUB 62310.

Voltages which are compatible with Digital Data Service are delineated in Technical Reference PUB 62507.

Issued: [DATE]
Effective: [DATE]
By: Brent Kennedy
Title: President and General Manager

SPECIAL ACCESS SERVICE

VI. DIGITAL DATA SERVICE (Continued)

C. Channel Interfaces

The following channel interfaces (CIs) define the bit rates that are available for a Digital Data circuit.

| CI | <u>Bit Rate</u> |
|-------|-----------------|
| DU-24 | 2.4 Kbps |
| DU-48 | 4.8 Kbps |
| DU-96 | 9.6 Kbps |
| DU-56 | 56.0 Kbps |

Compatible channel interfaces are set forth in Section 8 following.

D. Optional Features and Function

1. Central office Bridging Capability
2. Transfer Arrangement

An arrangement that affords the customer an additional measure of protection and/or flexibility in the use of their access circuit(s) on a 1xN basis. The arrangement can be utilized to transfer a leg of a Special Access Service to either a spare or working circuit that terminates in either the same or a different customer designated premises. This arrangement is only available at a Telephone Company designated hub. A key activated or dial-up control service is required to operate the transfer arrangement. A spare circuit, if required, is not included as a part of the option.

Issued: [DATE]
Effective: [DATE]
By: Brent Kennedy
Title: President and General Manager

SPECIAL ACCESS SERVICE

VI. DIGITAL DATA SERVICE (Continued)

E. Rates and Charges [See Section 14, VII.]

| | <u>Monthly Rate</u> | <u>Nonrecurring Charge</u> |
|----------------------------|--------------------------|--------------------------------|
| 1. Circuit Termination | | |
| - Per Point of Termination | [See Section 14, VII.A.] | |
| -2.4 Kbps | | |
| -4.8 Kbps | | |
| -9.6 Kbps | | |
| -56.0 Kbps | | |
| 2. Circuit Mileage | [See Section 14, VII.B.] | |
| - Fixed | | |
| -2.4 Kbps | | |
| 4.8 Kbps | | |
| 9.6 Kbps | | |
| 56.0 Kbps | | |
| - Per Mile | | |
| -2.4 Kbps | | |
| -4.8 Kbps | | |
| -9.6 Kbps | | |
| -56.0 Kbps | | |

Issued: [DATE]
Effective: [DATE]
By: Brent Kennedy
Title: President and General Manager

SPECIAL ACCESS SERVICE

VI. DIGITAL DATA SERVICE (Continued)

E. Rates and Charges [See Section 14, VII.] (Continued)

3. Optional Features and Functions
Monthly Rates and Nonrecurring Charges for the Optional Features and Functions of Digital Data Service listed in this section apply to all jurisdictions.

| <u>Optional Features and Functions</u> | <u>Monthly Rates</u> | <u>Nonrecurring Charges</u> |
|--|--------------------------|---------------------------------|
|--|--------------------------|---------------------------------|

a. Bridging – Per Port [See Section 14, VII.C.]

b. Loop Transfer Arrangement
(Key Activated* or Dial-Up**
-Per Four-Port Arrangement***)

* The key activated control is rated as a Metallic Circuit Termination and Circuit Mileage, if applicable.

** The Dial-Up option requires the customer to purchase the Controller Arrangement from Section 7, VII.A. following.

*** An additional Circuit Termination charge will apply whenever a spare circuit is configured as a leg to the customer's premises. Additional Circuit Mileage charges will also apply when the transfer arrangement is not located in the customer premises service wire center.

Issued: [DATE]
Effective: [DATE]
By: Brent Kennedy
Title: President and General Manager

SPECIAL ACCESS SERVICE

VI. DIGITAL DATA SERVICE (Continued)

E. Rates and Charges [See Section 14, Part VII.] (Continued)

4. Channel Service Unit [See Section 14, VII.D.]

Monthly Rates and Nonrecurring Charges for the Channel Service Unit* of Digital Data Service listed in this section apply to all jurisdictions.

| <u>Channel Service Limit*-</u> Per Point of Termination | <u>Monthly</u> <u>Rates</u> | <u>Nonrecurring</u> <u>Charges</u> |
|--|--------------------------------|---------------------------------------|
| | [See Section 14, VII.D.] | |
| - 2.4 Kbps | | |
| - 4.8 Kbps | | |
| - 9.6 Kbps | | |
| - 56.0 Kbps | | |

* Channel Service Units will only be provided under tariff if they existed in the Telephone Company's inventory as of November 18, 1983.

Issued: [DATE]
Effective: [DATE]
By: Brent Kennedy
Title: President and General Manager

SPECIAL ACCESS SERVICE

VII. HIGH CAPACITY SERVICE (Continued)

A. Basic Circuit Description

A High Capacity circuit is a circuit for the transmission of nominal 64.0 Kbps* or 1.544, 3.152, 6.312, 44.736 or 274.176 Mbps isochronous serial data. The actual bit rate is a function of the channel interface selected by the customer. High Capacity circuits are provided between customer designated premises or between a customer designated premises and a Telephone Company hub.

The customer may provide the Network Channel Terminating Equipment associated with the High Capacity circuit at the customer's premises. The interim program for interconnection of such equipment is set forth in Technical Reference PUB AS No. 1.

B. Technical Specifications Packages

| <u>Parameter</u> | | <u>Package HC</u> | | | |
|-------------------|---|-------------------|----|---|---|
| | 0 | 1 | 1C | 3 | 4 |
| Error-Free Second | | X | | | |

A circuit with technical specifications package HC1 will be capable of an error-free second performance of 98.75% over a continuous 24-hour period as measured at the 1.544 Mbps rate through a CSU equivalent which is designated, manufactured, and maintained to conform with the specifications contained in Technical Reference PUB 62411.

* Available only as a circuit of a 1.544 Mbps facility to a Telephone Company Digital Data hub or as a cross connect of two 2.4, 4.8, 9.8, 56.0 or 64.0 Kbps circuits of two 1.544 Mbps facilities to a Digital Data hub(s). The customer must provide system and channel assignment data.

Issued: [DATE]
Effective: [DATE]
By: Brent Kennedy
Title: President and General Manager

SPECIAL ACCESS SERVICE

VII. HIGH CAPACITY SERVICE (Continued)

C. Channel Interfaces

The following channel interfaces (CIs) define the bit rates that are available for a High capacity circuit:

| CI | <u>Bit Rate</u> |
|--------|--------------------|
| DS-15* | 1.544Mbps (DS1) |
| DS-27 | 274.176 Mbps (DS4) |
| DS-31 | 3.152 Mbps (DS1C) |
| DS-44 | 44.736 Mbps (DS3) |
| DS-63 | 6.312 Mbps (DS2) |

Compatible channel interfaces are set forth in Section 8, III.E.5 following.

D. Optional Features and Functions

1. Automatic Loop Transfer

The Automatic Loop Transfer provides protection on a 1xN basis against failure of the facilities between a customer designated premises and the wire center serving that premises. Protection is furnished through the use of a switching arrangement that automatically switches to a spare circuit line when a working line fails. The spare circuit is not included as a part of the option. This option requires compatible equipment at both the serving wire center and the customer premises. The customer is responsible for providing the equipment at its premises. Equipment at the customer premises will be provided under tariff only if it existed in the Telephone Company inventory as of November 18, 1983.

Issued: [DATE]
Effective: [DATE]
By: Brent Kennedy
Title: President and General Manager

SPECIAL ACCESS SERVICE

VII. HIGH CAPACITY SERVICE (Continued)

D. Optional Features and Functions (Continued)

2. Transfer Arrangement

An arrangement that affords the customer an additional measure of flexibility in the use of their access circuit(s). The arrangement can be utilized to transfer a leg of a Special Access Service to either a spare or working circuit that terminates in either the same or a different customer designated premises. A key activated or dial-up control service is required to operate the transfer arrangement. A spare circuit, if required is not included as part of the option.

* A 64.0 Kbps circuit is available as a circuit(s) of a 1.544 Mbps facility to a Telephone Company hub.

Issued: [DATE]
Effective: [DATE]
By: Brent Kennedy
Title: President and General Manager

SPECIAL ACCESS SERVICE

VII. HIGH CAPACITY SERVICE (Continued)

D. Optional Features and Functions (Continued)

3. Central Office Multiplexing

- a. DS4 to DS1 - An arrangement that converts a 274.176 Mbps circuit to 168 DS1 circuits using digital time division multiplexing.
- b. DS3 to DS1 - An arrangement that converts a 44.736 Mbps circuit to 28 DS1 circuits using digital time division multiplexing.
- c. DS2 to DS1 - An arrangement that converts a 6.312 Mbps circuit to four DS1 circuits using digital time division multiplexing.
- d. DS1C to DS1 - An arrangement that converts a 3.152 Mbps circuit to two DS1 circuits using digital time division multiplexing.
- e. DS1 to Voice - An arrangement that converts a 1.544 Mbps circuit to 24 circuits for use with Voice Grade Services. A circuit at this DS1 to the hub can also be used for a Digital Data Service.
- f. DS1 to DS0 - An arrangement that converts a 1.544 Mbps circuit to 23 64.0 Kbps circuits utilizing digital time division multiplexing.

Issued: [DATE]
Effective: [DATE]
By: Brent Kennedy
Title: President and General Manager

SPECIAL ACCESS SERVICE

VII. HIGH CAPACITY SERVICE (Continued)

D. Optional Features and Functions (Continued)

3. Central Office Multiplexing (Continued)

- g. DSO to Subrate - An arrangement that converts a 64.0 Kbps circuit to subspeeds of up to 20. 2.4 Kbps, ten 4.8 Kbps, or five 9.6 Kbps circuits using digital time division multiplexing.

The following table shows the technical specifications packages with which the optional features and functions are available.

| | <u>Available with Technical Specifications Package HC-</u> | | | | |
|------------------------------|--|---|---|---|---|
| | 0 | 1 | 2 | 3 | 4 |
| Automatic Loop Transfer | | X | | | |
| Central Office Multiplexing: | | | | | |
| DS4 to DS1 | | | | X | |
| DS3 to DS1 | | | X | | |
| DS2 to DS1 | | | X | | |
| DS1C to DS1 | | | X | | |
| DS1 to Voice | | X | | | |
| DS1 to DS0 | X | | | | |
| DS0 to Subrate* | X | | | | |
| Transfer Arrangement | | X | | | |

* Available only on a circuit of 1.544 Mbps facility to a Telephone Company hub.

Issued: [DATE]
 Effective: [DATE]
 By: Brent Kennedy
 Title: President and General Manager

SPECIAL ACCESS SERVICE

VII. HIGH CAPACITY SERVICE (Continued)

E. Rates and Charges [See Section 14, VIII.]

| | <u>Monthly Rates</u> | <u>Nonrecurring Charges</u> |
|--|--------------------------|---------------------------------|
| 1. Circuit Termination | | |
| - Per Point of Termination -1.544 Mbps | | [See Section 14, VIII.A.] |
| - Per Point of Termination -frequency bandwidths other than 1.544 Mbps | | |

Monthly Rates and Nonrecurring Charges for the Circuit Termination rate element of High Capacity Service for all jurisdiction will be determined on an Individual Case Basis.

Available frequency bandwidths for years 1-1-89 to 1-1-90 are as follows:

Frequency
Bandwidths
64 Kbps
3.152 Mbps
6.312 Mbps
44.736 Mbps
274.176 Mbps

Issued: [DATE]
Effective: [DATE]
By: Brent Kennedy
Title: President and General Manager

SPECIAL ACCESS SERVICE

VII. HIGH CAPACITY SERVICE (Continued)

E. Rates and Charges [See Section 14, VIII.] (Continued)

Monthly Rates

[See Section 14, VIII.]

2. Circuit Mileage

-1.544 Mbps

Fixed

-Per Mile

Circuit Mileage

For frequency bandwidths

-other than 1.544 Mbps:

Fixed and Per Mile Monthly Rates for the Circuit Mileage rate element of High Capacity Service for all jurisdictions will be determined on an Individual Case Basis and filed in VIII. following.

Available frequency bandwidths formats for years 1-1-89 to 1-1-90 are as follows.

Frequency

Bandwidths

64 Kbps

3.152 Mbps

6.312 Mbps

44.736 Mbps

274.176 Mbps

Issued: [DATE]
Effective: [DATE]
By: Brent Kennedy
Title: President and General Manager

SPECIAL ACCESS SERVICE

VII. HIGH CAPACITY SERVICE (Continued)

E. Rates and Charges [See Section 14, VIII.] (Continued)

3. Optional Features and Functions [See Section 14, VIII.]

| | <u>Monthly Rates</u> | <u>Nonrecurring Charges</u> |
|-------------------------------|--------------------------|---------------------------------|
| a. Multiplexing | | |
| DS4 to DS1 | | [See Section 14, VIII.C.1.] |
| -Per arrangement | | |
| DS3 to DS1 | | |
| -Per arrangement | | |
| DS2 to DS1 | | |
| -Per arrangement | | |
| DS1C to DS1 | | |
| -Per arrangement | | |
| DS1 to Voice* | | |
| -Per arrangement | | |
| DS1 to DS0 | | |
| -Per arrangement | | |
| DS0 to Subrates | | |
| -Per arrangement | | |
| Up to 20 2.4 Kbps services | | |
| Up to 10 4.8 Kbps services | | |
| Up to 5 9.6 Kbps service | | |

* A circuit of this DS1 to the hub can be used for Digital Data service. ICB rates and charges are filed in VIII. following.

Issued: [DATE]
Effective: [DATE]
By: Brent Kennedy
Title: President and General Manager

SPECIAL ACCESS SERVICE

VII. HIGH CAPACITY SERVICE (Continued)

E. Rates and Charges [See Section 14, VIII.] (Continued)

3. Optional Features and Functions [See Section 14, VIII.]
(Continued)

Monthly Rates

[See Section 14, VIII.C.2.]

Automatic Loop Transfer
-Per arrangement*

4. Transfer Arrangement
(Key Activated**
or Dial-Up***)
-Per Four-port arrangement,
including control channel
termination****)

[See Section 14, VIII.C.3.]

Network Channel Terminating
Equipment (NCTE)#
-Per point of Termination
Where provided
-1.544 Mbps

[See Section 14, VIII.C.4.]

-Automatic Loop Transfer

* An additional Circuit Termination charge will apply whenever the spare line is provided as a let to the customer premises.

** The key activated control circuit is rated as a Metallic Circuit Termination.

*** The Dial-Up option requires the customer to purchase the Controller Arrangement from Section 12 following.

**** An additional Circuit Termination charge will apply whenever a spare circuit is configured as a let to the customer's premises. Additional circuit mileage charges will also apply when the transfer arrangement is not located in the customer premises serving wire center.

NCTE will only be provided under tariff if it existed in the Telephone Company's inventory as of November 18, 1983.

Issued: [DATE]
Effective: [DATE]
By: Brent Kennedy
Title: President and General Manager

SPECIAL ACCESS SERVICE

VIII. INDIVIDUAL CASE FILING [See Section 14, XIV.]

Rates and charges for Special Access Service may be provided on an individual case basis.

Issued: [DATE]
Effective: [DATE]
By: Brent Kennedy
Title: President and General Manager